

ZONE VIBE WIRELESS

Setup Guide
Guide d'installation

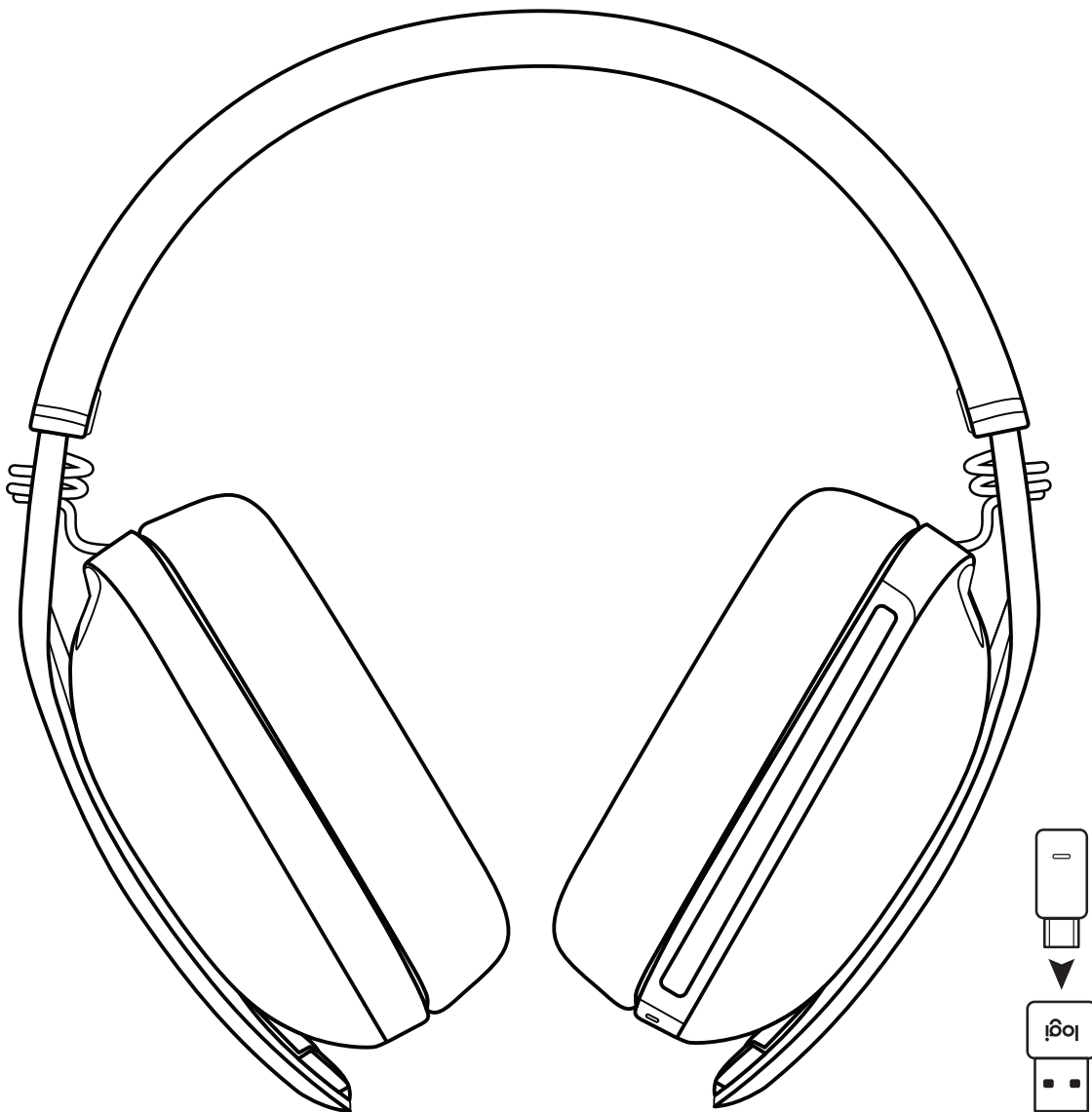

CONTENTS

English 3

Français 14

Español. 25

Português 36

KNOW YOUR PRODUCT

Front view:

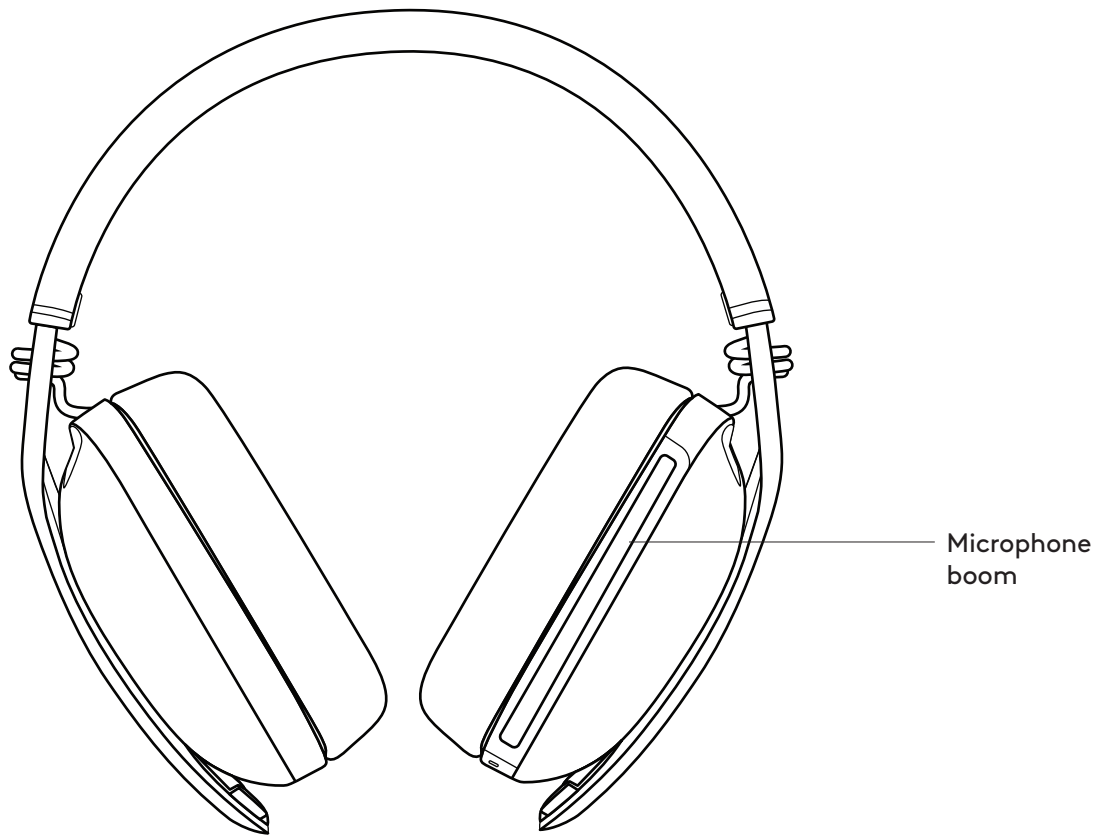

Back view:



Bottom view:

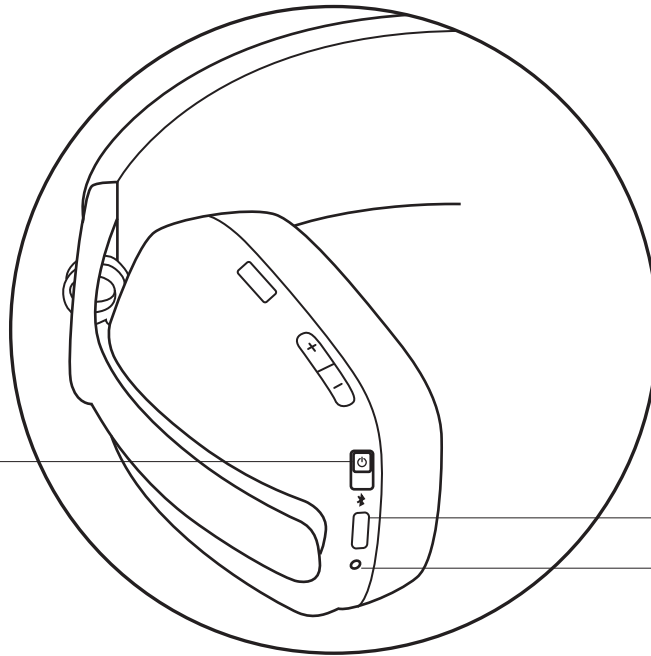

3-position switch (power /
Bluetooth[®] pairing)

USB-C port

LED light

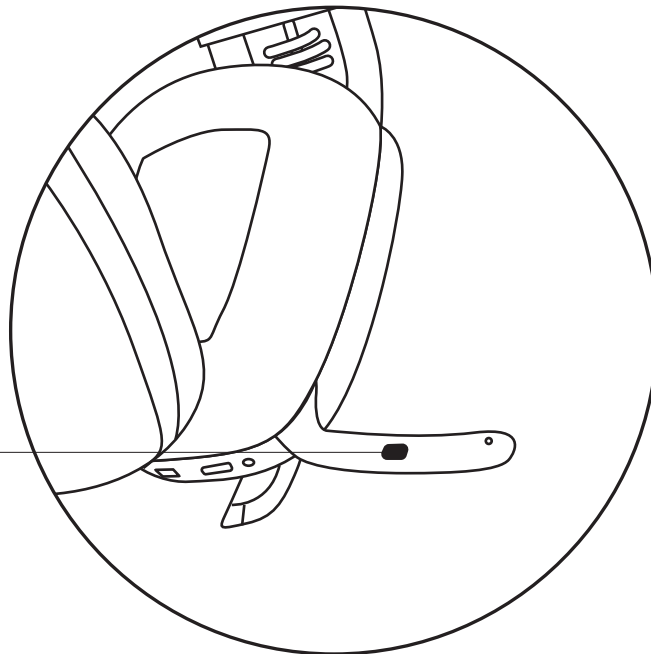

Mute button

BOX CONTENT

1. Zone Vibe Wireless headphones
2. Charging cable
3. USB-C receiver
4. USB-A adapter
5. Travel bag
6. User documentation

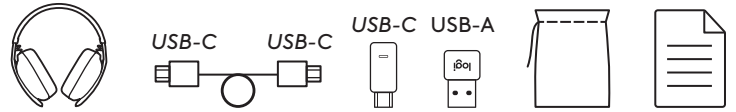

POWER ON / OFF

1. Slide the switch in the arrow's direction to the middle to power on the headphones.

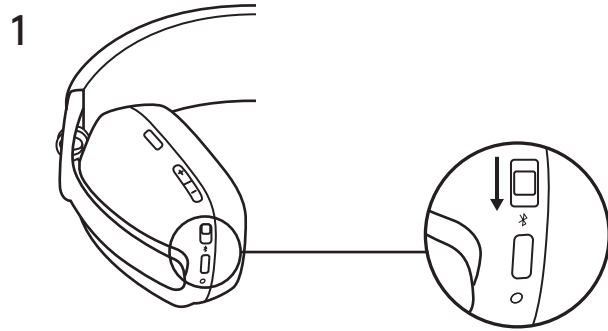

2. Once powered on, the LED light will slightly turn white.
3. There will be a voice prompt that tells you the battery status.

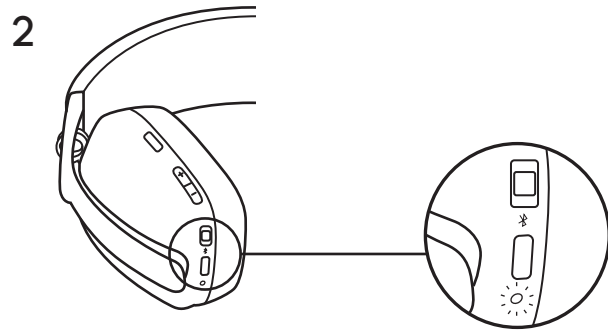

CONNECT YOUR HEADPHONES

a. Connect via **USB-C** receiver

1. Insert the receiver into the computer **USB-C** port. Or insert the **USB-C** receiver with the **USB-A** adapter to the **USB-A** port.
2. Zone Vibe Wireless is already paired to the receiver it ships with.
3. Once successfully paired, the LED light on the receiver will turn solid white then dim.

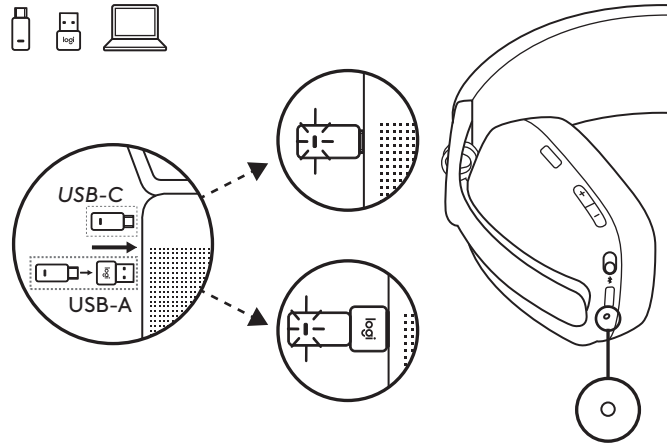

b. Connect via **BLUETOOTH**[®]

1. Slide the switch to the bottom in the arrow's direction for 2 seconds to initiate pairing.
2. The LED light will flash white rapidly.
3. Open **Bluetooth**[®] settings on your device.
4. Select Logi Zone Vibe Wireless in discoverable devices.
5. Once successfully paired, the LED light will turn solid white.

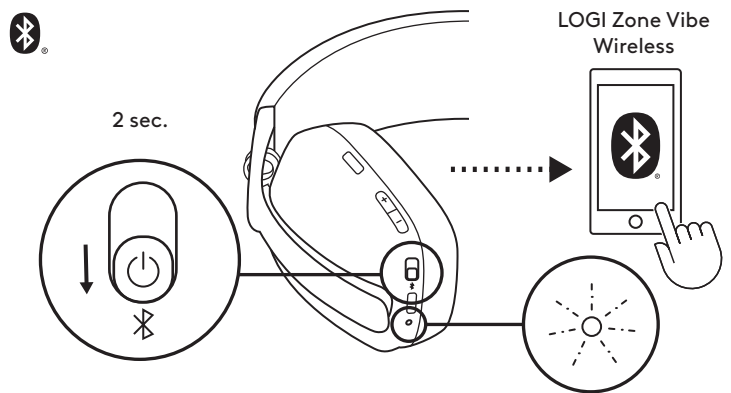

ADJUSTING HEADPHONES

1. Adjust the headphones by sliding earcups up and down the extended part of the headband.
2. It may be easier to adjust the headphones on your head. Slide the earcups up and down the headband until they sit comfortably on your ears.

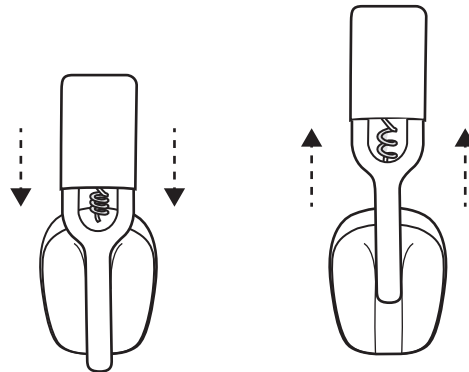

HEADPHONES CONTROLS

MSFT Teams:			
	Usage	Button	Action
Call controls	Answer / End call	Call button	Short press
	Reject call		1.5 sec. press
	Resume call		Short press
	Transfer active call to other device		
Team activities	Invoke Teams	Call button	Short press
Music controls	Play / Pause	Music control button	Short press
	Track forward		Double press
Volume	Volume up	"+"	Short press
	Volume down	"_"	
Connectivity	Bluetooth pairing	Power button	2 sec. press

UC version:			
	Usage	Button	Action
Call controls	Answer / End call	Call button	Short press
	Reject call		1.5 sec. press
Music controls	Play / Pause	Music control button	Short press
	Track forward		Double press
Volume	Volume up	"+"	Short press
	Volume down	"_"	
Connectivity	Bluetooth pairing	3-position switch	2 sec. press

Note:

- Teams activities are only functional when Teams is running on an unlocked computer.
- Media control functionality depends on the type of application.
- Call activities are always the first priority. When two devices are connected, the *Bluetooth*® connection will be prioritized over the receiver. When two Bluetooth devices are connected, the last active device will override the other.

Tip: Music EQ controls available on Logi Tune.

MUTE

There are 2 ways to mute your microphone.

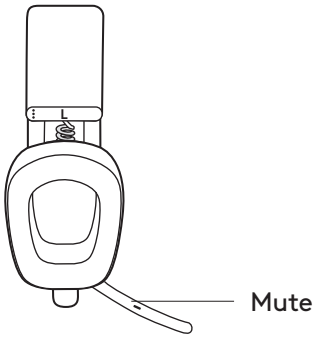

Press the button to mute.



Flip up or down the mic boom to mute or unmute.



Voice notifications indicate when the microphone is on / off mute.

HEADPHONES LIGHT INDICATOR

	Category	Status	Light
White	Power	Power ON	Turn solid white and then dim
		Battery charging	Breathing
		Battery fully charged	Solid and then off
	Connectivity	Bluetooth pairing	Fast blinking
		Bluetooth / receiver connected	Turn solid white and then dim
	Calls	Active call	Solid
Incoming call		Slow blinking	
Red	Calls	Mute	Solid
	Power	Low battery (< 10%)	Slow blinking
		Factory reset	Fast blink from red to white for three times then LED turn off

Note:

- User-triggered behaviors, such as Bluetooth pairing, will be prioritized then revert back to its previous status once the behavior is completed.

RECEIVER LIGHT INDICATOR

MSFT Teams:			
	Category	Status	Light
White	Connectivity	Receiver connecting	Off
		Receiver connected New device paired	Turn solid white and then dim
		Receiver disconnected	Off
	Calls	Active call	Solid
		Incoming call	Repeat "fast blinking 3 times then LED off"
Purple	Connectivity	Connecting to Teams	Breathing
			Solid
		First time failed connecting to Teams	Fast blinking for 10 seconds and then off
Failed connecting to Teams	Fast blinking 3 times then LED off		
Red	Calls	Mute	Solid
Blue	Connectivity	New device pairing	Fast blinking

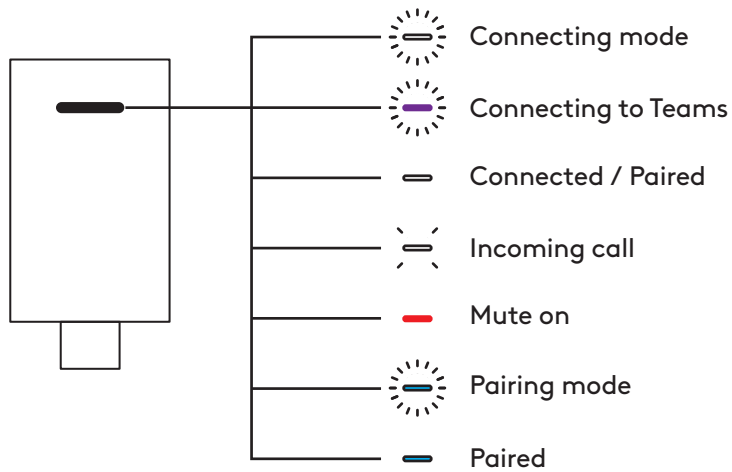

UC version			
	Category	Status	Light
White	Connectivity	Receiver connecting	Off
		Receiver connected New device paired	Turn solid white and then dim
		Receiver disconnected	Off
	Calls	Active call	Solid
		Incoming call	Repeat "fast blinking 3 times then LED off"
Red	Calls	Mute	Solid
Blue	Connectivity	New device pairing	Fast blinking

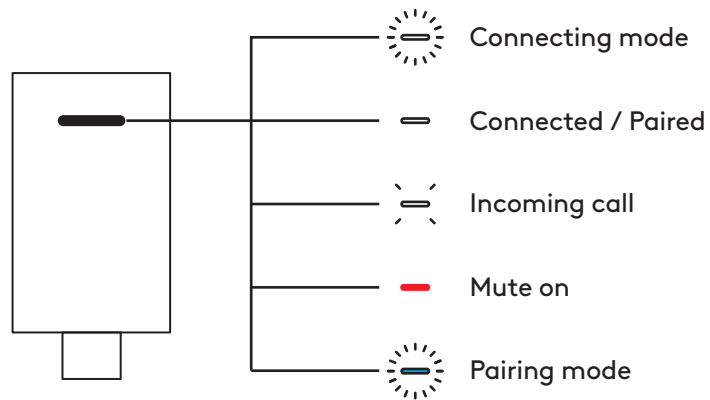

CHARGING

To conserve battery life, headphones automatically power off after 30 minutes without usage.

Sleep timer can be adjusted in Logi Tune.

The LED light on the headset will blink slowly in RED when the battery is lower than 10%.

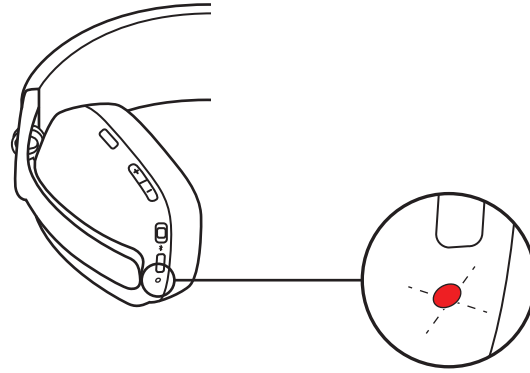

Charging via USB cable

1. Plug one end of the cable to the *USB-C* port on the bottom of the earcup and the other end into the *USB-C* charging port on your computer.
2. The LED light will start breathing white when charging.
3. The LED light will turn solid white when fully charged.
 - 2 hours will fully charge the battery.
 - 5 minutes will give you 1 hour of playback.

Note:

Battery life may vary based on user, environment, and computing conditions.

4. The headphones can be used with the receiver and Bluetooth paired while charging.

LOGI TUNE

Logi Tune helps boost your headphones performance with periodic software and firmware updates.

It is recommended to update both your headphones and receiver. To do so, download Logi Tune from www.logitech.com/tune



ADJUSTING SIDETONE

Sidetone lets you hear your own voice during conversations so you are aware of how loud you are talking. In Logi Tune, select the sidetone feature, and adjust the dial accordingly.

- A higher number means you hear more external sound.
- A lower number means you hear less external sound.

AUTO SLEEP TIMER

By default, your headphones will automatically power off when not in use for 30 minutes. Adjust the sleep timer in Logi Tune. To wake up your headphones, try sliding off/on the power switch again.

RESET YOUR HEADPHONES

1. Power the headphones on.
2. Press and hold the call button and volume '-' button for 5 seconds.
3. The LED light will quickly blink from red to white for 3 times and then turns off when your headset are successfully reset.
4. The headphones will turn off after reset.

DIMENSIONS

Headphones:

Height x Width x Depth: 183.03 x 169.68 x 73 mm

Weight: 0.185 Kg

Earpad:

Height x Width x Depth: 98.6 x 75.44 x 19.3 mm

Receiver:

Height x Width x Depth: 26.8 x 12.4 x 6.2 mm

Adapter:

Height x Width x Depth: 24.5 x 15.4 x 8.7 mm

SYSTEM REQUIREMENTS

Works with common calling applications across almost all platforms and operating systems.

Works with *Windows*, *Mac*, or *Chrome*-based computer via *USB-C*, *USB-A*, *Bluetooth*[®] and *iOS* or *Android* Bluetooth-enabled devices.

TECHNICAL SPECIFICATIONS

Microphone Type: Dual omni-directional MEMS mics with directional beamforming and DSP

Frequency response (Speaker): 20-20kHz (music mode), 100-8kHz (talk mode)

Frequency response (Microphone): 100-8kHz

Talk time up to 18 hrs

Listen time up to 20 hrs

Bluetooth version (headphones): 5.2

Bluetooth version (receiver): 5.2

Wireless range: Up to 50 m / 164 ft (open field line of sight)

Cable length (*USB C* to *C* charging cable): 4.9 ft (1.5 m)

www.logitech.com/support/zoneibewireless